

# RAZE

## RAZE PRO-V2 ELECTRIC CHAIN HOIST

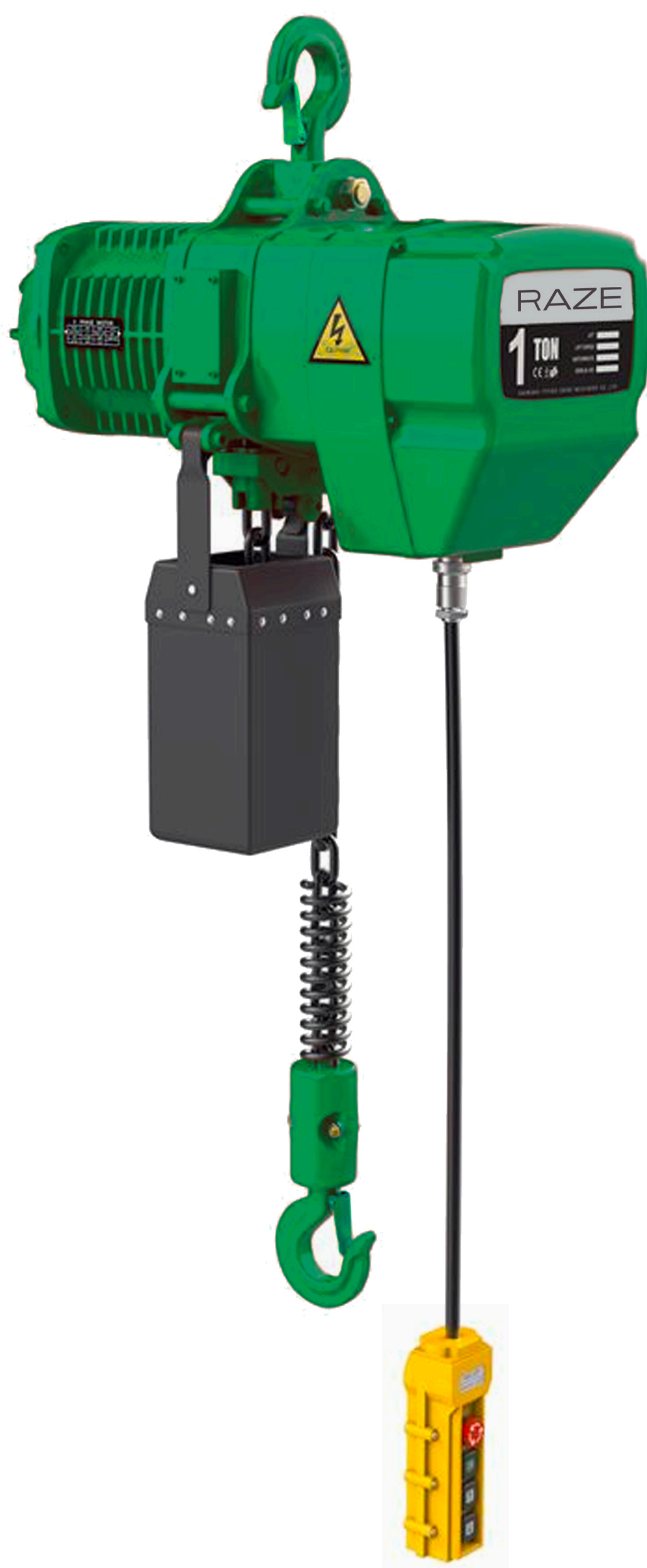



# RAZE PRO-V2

## STANDARD FEATURES

Mechanical load brake assures braking even under overload conditions

Electric controls feature magnetic circuit breakers instead of fuses. In case of overload trip, the circuit breaker can be easily reset, eliminating the need to replace fuses. Phase error relay protection is also provided to prevent the motor from running when wired incorrectly. Variable frequency controls are available

Hoist motor features aluminum alloy cast housing for optimal motor heat dissipation and to reduce overall hoist height



Electro-Magnetic Brake provides instant braking and releasing of the full load upon push button command

Heavy duty chain bag comes standard with all units

Upper and lower travel limit switches prevent the load from being raised too high and the chain running out

2 push button pendant with emergency stop is durable, light weight, and water-proof. Power to pendant control transformed to 115v to ensure safe operation in case of short circuit

Grade 80 case hardened alloy steel chain endures harsh conditions

Forged steel 360° swivel hook with safety latch





# RAZE PRO-V2

## ELECTRIC CHAIN HOIST

### Product Introduction

#### Standard Features Include:

- Dual Speed
- Grade 80 case hardened alloy steel chain
- Aluminum alloy casting, features rigid structure and light weight
- Motor framed with radiant cooling fins, permits (dual speed 40/20%, 15%) duty cycle
- Electro-Magnetic Brake Controller, features simultaneous braking upon release of P.B. even under full load
- Limit Switch - Fitted at both top and bottom ends, shuts off power automatically to prevent load chain from running out
- Mechanical Brake - Advanced design, assures secure braking even under overload. In conjunction with motor brake, features "DOUBLE BRAKE SYSTEM" for safety and durability in hoist operation
- Magnetic Contactor - High performance non-fuse circuit breakers allow frequent trouble cycling with free operation
- Phase Error Relay - A specially designed electric board prevents motor from running at it reverse phased

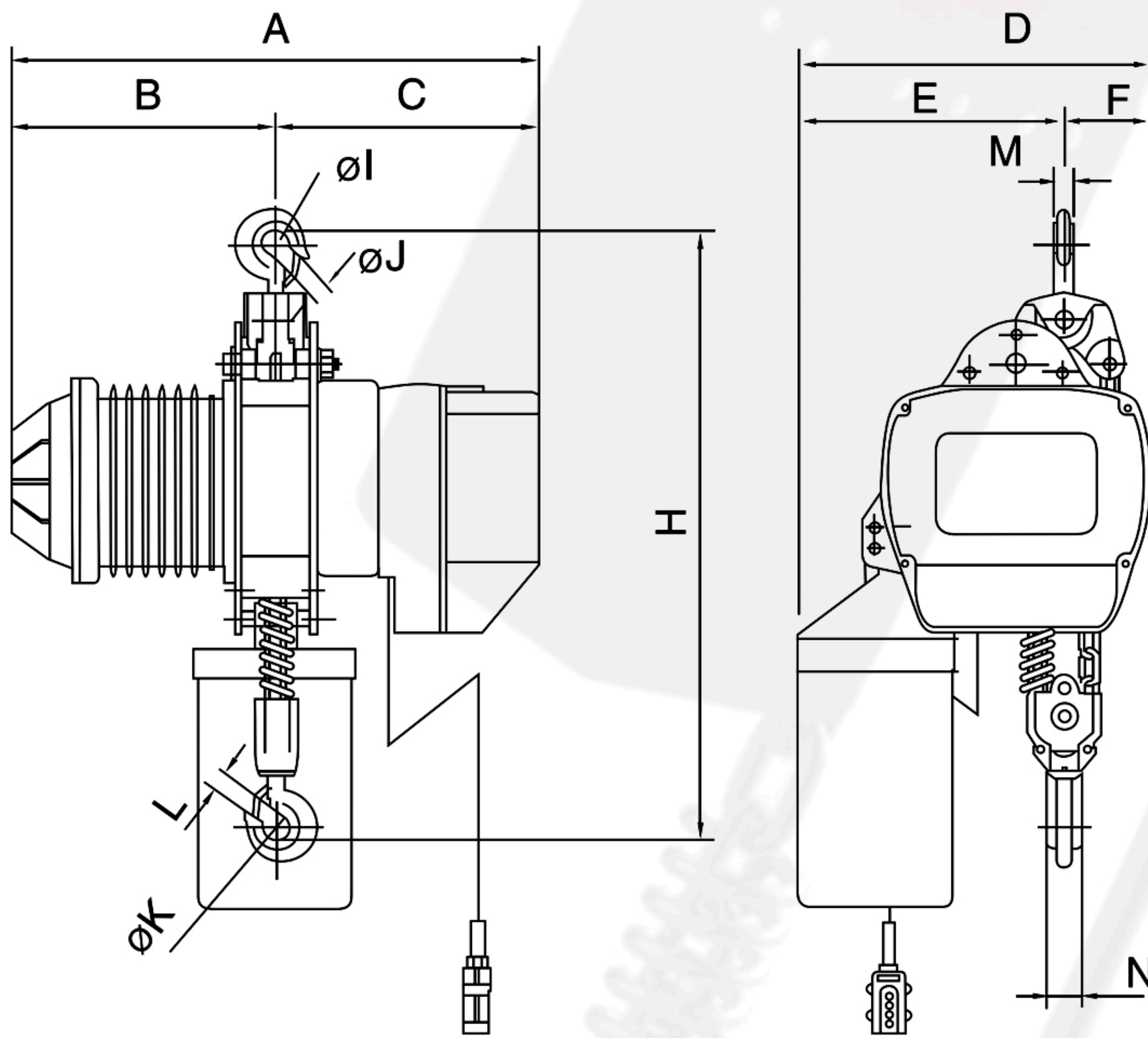
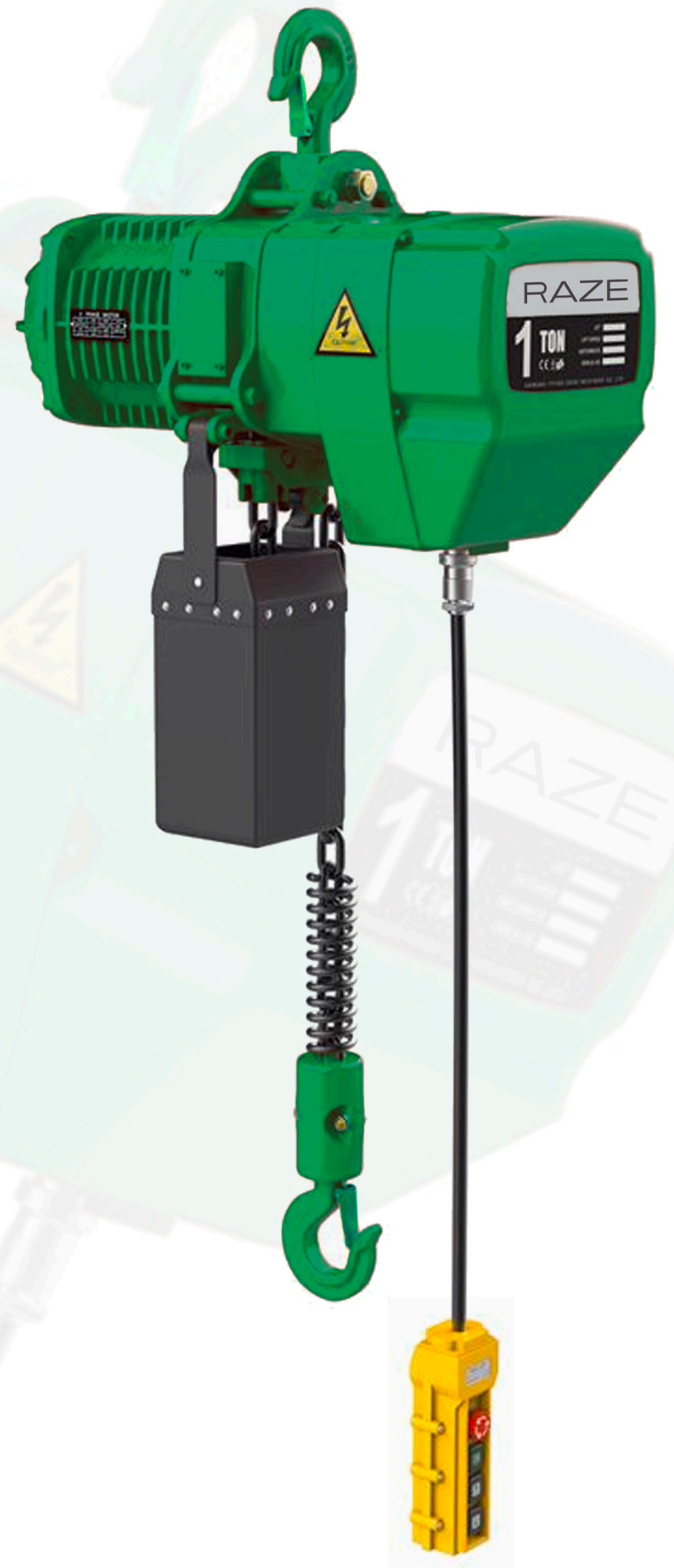

MODEL	CAPACITY (TONS)	LIFT (FT)	WEIGHT (LB)	SPEED (FPM)	CHAIN FALLS	HP	AMPS	
							230V	460V
RZD-050	1/2	20	121	26/9	1	2.4	8.6/6.8	4.5/3.8
RZD-100	1	20	121	18/6	1	2.4	8.6/6.8	4.5/3.8
RZD-200	2	20	142	9/3	2	2.4	8.6/6.8	4.5/3.8
RZD-300	3	20	309	17/6	2	5	18/12	10/7.2
RZD-500	5	20	337	11/4	2	5	18/12	10/7.2

MODEL	DIMENSIONS (IN)												
	H	A	B	C	D	E	F	I	J	K	L	M	N
RZD-050	23.43	19.88	9.65	10.24	9.45	4.53	4.92	1.58	1.10	1.58	1.10	0.91	0.91
RZD-100	23.43	19.88	9.65	10.24	9.46	4.53	4.92	1.58	1.10	1.58	1.10	0.91	0.91
RZD-200	29.33	19.88	9.65	10.24	9.45	6.89	2.56	1.81	1.42	1.81	1.42	1.22	1.22
RZD-300	37.80	25.20	12.83	12.36	17.64	13.39	4.25	2.05	1.69	2.05	1.69	1.39	1.39
RZD-500	40.55	25.20	12.83	12.36	17.64	14.02	3.60	2.44	1.77	2.44	1.77	1.77	1.77