

# RAZE

## RZHC CHAIN BLOCK

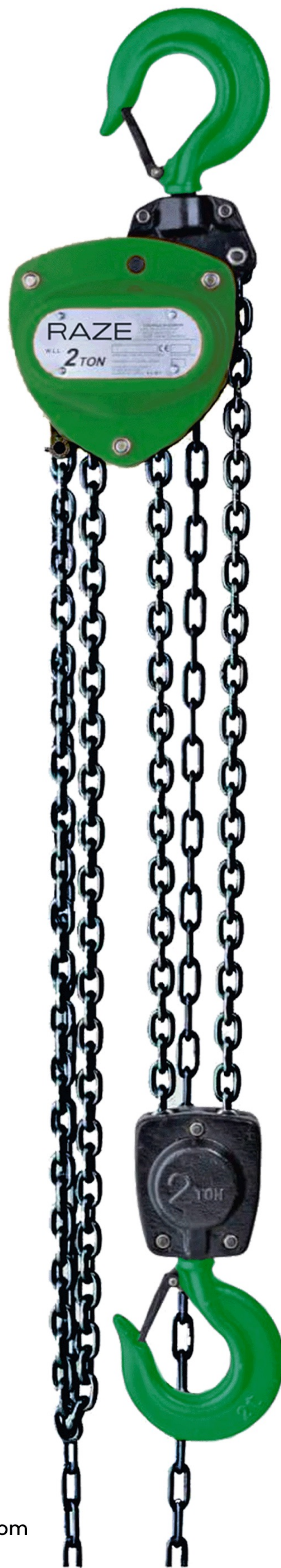

# RZHC

## CHAIN BLOCK

### Product Introduction

- Meets all pertinent world standards
- Compact design for limited headroom applications
- High strength steel frame and gear case built to be durable for the rugged needs of construction and maintenance rigging
- Heat-treated spur gear efficiently designed to provide smooth load handling and low hand chain pull
- Reinforced double pawl brake system and larger diameter pawl springs ensure reliable brake
- Open frame design for self-cleaning, quick load sheave inspection and easy hoist maintenance
- Grade 80 Premium Alloy Steel Chain

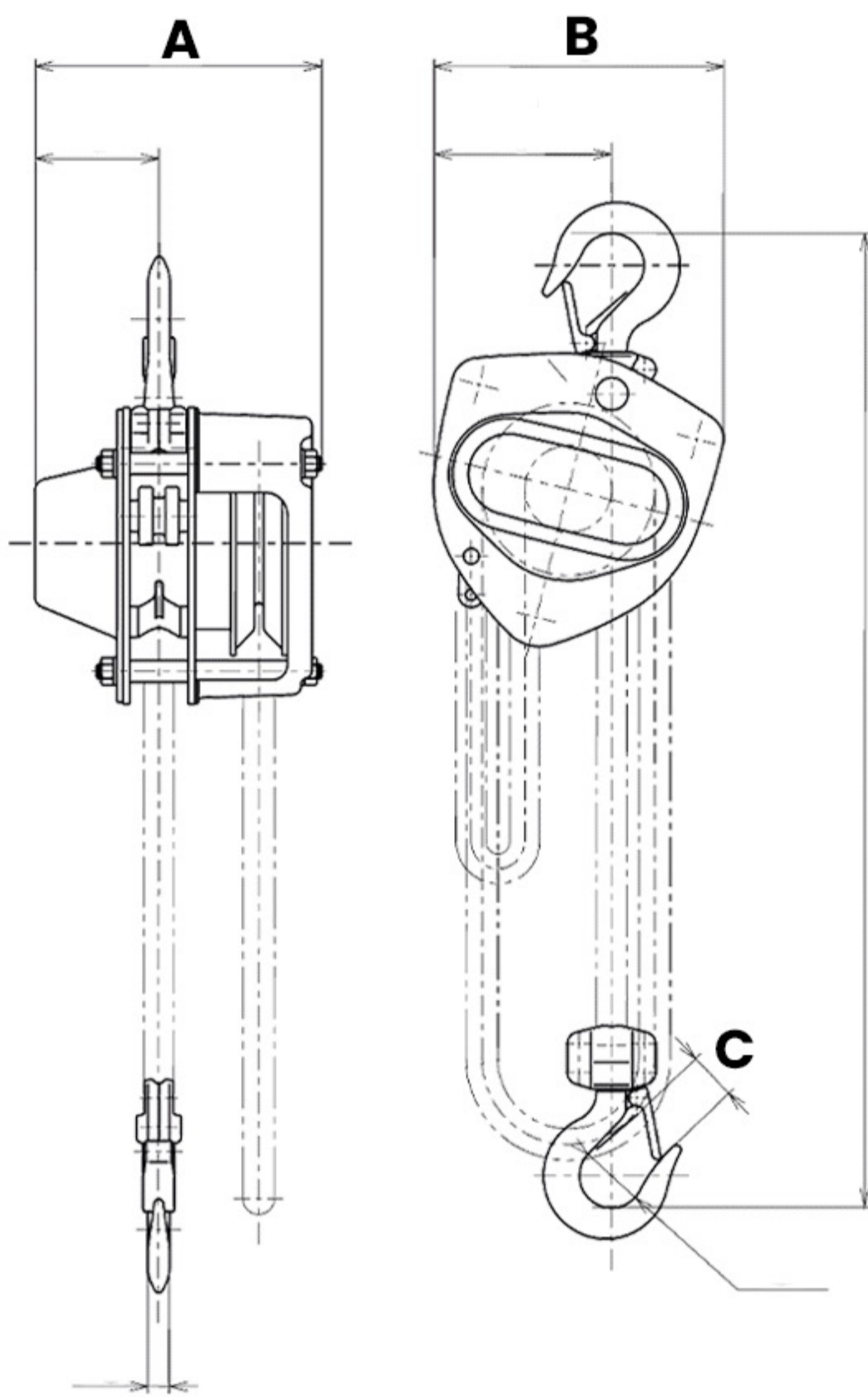

MODEL	CAPACITY (TON)	LIFT (FT)	CHAIN FALLS	LOAD CHAIN DIAMETER (MM)	DIMENSIONS (IN)				NET (LB) WEIGHT
					A	B	C	H	
RZHC-05-10	1/2	10	1	5	5.20	5.83	1.10	13.58	24
RZHC-05-15	1/2	15	1	5	5.20	5.83	1.10	13.58	29
RZHC-05-20	1/2	20	1	5	5.20	5.83	1.10	13.58	34
RZHC-1-10	1	10	1	6	5.94	6.77	1.26	14.80	27.5
RZHC-1-15	1	15	1	6	5.94	6.77	1.26	14.80	33.5
RZHC-1-20	1	20	1	6	5.94	6.77	1.26	14.80	39.5
RZHC-2-10	2	10	1	8	6.89	8.27	1.42	18.50	43
RZHC-2-15	2	15	1	8	6.89	8.27	1.42	18.50	51
RZHC-2-20	2	20	1	8	6.89	8.27	1.42	18.50	59
RZHC-3-10	3	10	1	1	6.93	9.06	1.81	22.24	64
RZHC-3-15	3	15	1	1	6.93	9.06	1.81	22.24	74
RZHC-3-20	3	20	1	1	6.93	9.06	1.81	22.24	84
RZHC-5-10	5	10	2	9	7.44	11.02	1.81	27.09	91
RZHC-5-15	5	15	2	9	7.44	11.02	1.81	27.09	107
RZHC-5-20	5	20	2	9	7.44	11.02	1.81	27.09	123
RZHC-10-10	10	10	4	9	7.44	18.23	2.24	30.12	173
RZHC-15-15	10	15	4	9	7.44	18.23	2.24	30.12	206
RZHC-10-20	10	20	4	9	7.44	18.23	2.24	30.12	239